

WHITE PAPER

Information from EFD Induction

How induction heating
saves time and money for
the offshore industry



Photo : Technip Norge AS

CONTENTS

Click on a section to jump to it

The challenges.....	2
The solution.....	3
Why induction heating is suitable for offshore applications.....	4
Case studies from the offshore industry.....	6
Platform-based case story #1	7
Platform-based case story #2	8
Land-based case story	10
Subsea case story	12
How induction works.....	15
The induction coil—a critical component.....	18



The challenges

The application of heat is often the only way to repair, remove or install equipment essential to offshore operations. Unfortunately, traditional heating methods and offshore operations don't mix well. Safety concerns make the application of heat problematic. The use of gas-fired open flames, for example, is prohibited in many environments. If alternative heating methods are not employed, equipment may have to be disassembled and shipped ashore, driving up costs and perhaps even threatening production.

Then there are the problems posed by harsh environments and hard-to-reach work sites. The equipment used to generate, apply and control heat must be rugged enough to withstand punishing conditions, yet small and light enough to be easily and cost-effectively transported. Finally, many heating methods require at least partial production shutdowns—bad news in an industry where even minutes of lost output mean thousands of lost dollars.

The solution

Induction heating has long been an accepted heating method in numerous industries. The method itself was revolutionized in the 1980s by Elva, a Norwegian company that went on to form part of EFD Induction, today Europe's largest induction heating company. Elva's innovations centered on the use of solid-state electronics in induction heating systems. This enabled Elva to develop smaller, lighter, safer and more reliable induction heating solutions.

EFD Induction equipment and solutions are today used throughout the offshore industry for applications such as:

- Pre-weld heat treatment
- Post-weld heat treatment
- Pre-heating before coating
- Tube bending
- Shrink fitting and removal
- Removal of paint and coatings
- Curing of coatings
- Pre-heating prior to cladding
- Pre- and postheating of swaged ends
- Pre-weld heating for subsea hot tapping



An example of induction pre-heating: the pipe is being heated prior to receiving an anti-corrosive coating.

Why induction heating is suitable for offshore applications

Induction heating is characterized by features that make it ideal for offshore-related tasks:

Flameless

Induction heating is completely flame-free. In fact, induction heating is not strictly speaking a heat application method, as it does not involve applying external heat. Instead, induction heating is a heat generation technology—it induces heat internally in selected areas of a workpiece. This feature has been crucial to the rise in popularity of induction heating in the offshore industry.

Precise

Induction exploits the laws of electro-magnetism in order to produce heat in very accurately defined areas. The temperatures achieved by induction are also accurately controlled and easily adjusted. These features make it straightforward to pre-program specific heating cycles, and to repeat them automatically with virtually zero deviations.

Mobile

The miniaturization of electronic components has made it possible to build small yet powerful induction heating systems. For example, EFD Induction's Minac 25/40 (the model most commonly used for on-platform tasks such as shrink-fitting) weighs only 60 kg, and measures a compact 345 x 708 x 453 mm—yet can still deliver a constant power output of 25 kW, and up to 40 kW intermittent maximum power.



An EFD Induction mobile Minac system in action in the offshore industry. In this photo the power being applied to the workpiece is controlled by an easy-to-use handheld transformer.

WHITE PAPER from EFD Induction

Versatile

Induction heating can be used on virtually any electrically conductive material. Moreover, coils can be customized to fit a wide range of workpiece shapes and dimensions. This means that a single induction heater—an EFD Induction mobile Minac system, for instance—can be used for various applications and workpieces.



Many Minac models are available with two independent coils. These 'Twin' versions are essentially two induction heating systems in one. The coils can simultaneously perform completely different tasks using completely different process parameters.

Case studies from the offshore industry

The use of induction heating in the offshore industry falls into three broad categories: on a vessel (platform or ship), on land, subsea. The first category usually means the use of a mobile heating system for applications such as shrink fitting, tube bending, straightening and bolt expansion. The second category typically involves the use of induction heating at a spooling base or other land-based installation. The applications involved include pre- and post-weld heat treatment, as well as the pre-heating of pipe prior to the application of protective coatings. The third category, subsea, refers to the use of induction heating for subsea 'hot tapping', a specialized welding technique that allows branches to be welded to live pipes without any loss in production.



The 'Safe Concordia' accommodation and support platform. A mobile EFD Induction Minac system was used to pre-heat the weld area during the welding of a patch onto a crane tower.

Platform-based case story #1

Mobile heating equipment from EFD Induction was used to help repair a steel bulkhead on the 'Safe Concordia' accommodation and support platform.

The equipment—an EFD Induction mobile Minac 25/40—pre-heated the weld area before and during the welding of a 40mm-thick steel patch onto one of the platform's crane towers. To ensure optimal weld results, the weld area needed to be pre-heated to 80-100 °C, then maintained at that temperature throughout the entire welding process.

Such weld pre-heating is often carried out using resistance heating pads or mats. But as Jon Philpott, the EFD Induction engineer who performed the pre-heating explains, the presence of high-voltage cables near the weld area ruled out resistance heating. "Induction is not only flame-free, it is also extremely fast and localized. This means induction heating results in minimal stray heating and heat soak, especially when compared to resistance heating."

The contractor chosen to weld the patch, Whittaker Engineering, tested the EFD Induction equipment at its base outside Aberdeen, Scotland. "The offshore industry has tough safety and quality standards," says Ken Whittaker, Whittaker Engineering's co-founder. "EFD Induction had to first prove their solution could do the job while satisfying these requirements. Once that was achieved, the equipment, together with an EFD Induction offshore engineer, set off for Curaçao in the Caribbean. I'm more than happy with the result, and with the cooperation between us and EFD Induction."

Built by Keppel Fels in 2005, the 'Safe Concordia' is a six-column, semi-submersible accommodation platform with capacity for up to 455 persons. The platform is owned by Prosafe, the world's leading owner and operator of accommodation/service rigs. The company owns eleven semi-submersibles and one jack-up.

Accommodation/service rigs have traditionally been used wherever there is a need for additional accommodation, engineering, construction or storage capacity offshore. Typically, these rigs will be employed for installing and commissioning new facilities, upgrading or maintaining existing installations, hooking-up satellite fields to existing infrastructure, and removing installations.

Platform-based case story #2

Adair Swan and his colleagues at Rolls-Royce had a problem. They wanted to carry out maintenance work on a Rolls-Royce gas generator located on a BP rig in the North Sea. It was clear that heat would be needed to remove the various components—thrust collar, auxiliary gear, coupling hub—attached to the generator’s power turbine shaft. But because the generator was located in a designated hazard zone, any use of open flames such as a gas torch would shut down production.



Using induction to shrink-fit components on a North Sea platform.

Naturally keen to avoid a costly shutdown, Swan contacted EFD Induction UK to see if induction heating could be used. Paul Evans of EFD Induction UK tells what happened next. “Our first

job was to show we could meet the stringent safety standards set by Rolls-Royce and BP for on-platform heating. To do this we organized a successful workshop trial of our equipment. BP and Rolls-Royce then asked for an offshore trial on a redundant package of the Bruce platform.”

Located 380 km northeast of Aberdeen on the Scottish east coast, the Bruce Field is one of the largest gas/condensate (light oil) fields in production in the UK North Sea. Plans for the on-site trial were moving ahead when fate dramatically intervened. Jon Philpott, EFD Induction UK Offshore Application Manager explains: “Just before the planned offshore trial there was an unscheduled shutdown of a power turbine rotor on the Bruce platform. Our equipment and an EFD Induction engineer were rushed to the rig to heat and remove the turbine’s thrust collar, auxiliary gear and coupling hub from the turbine rotor. Once a new rotor was installed, the engineer used induction heating to reassemble the components.”

WHITE PAPER

from EFD Induction

Induction: the new standard

The emergency intervention by EFD Induction on the Bruce Platform was a great success. In fact, according to Rolls-Royce, the use of EFD Induction “resulted in the work being completed early and production restored several days ahead of schedule.” But the story doesn’t end there. Due to the proven success of the Bruce Platform project, induction heating has been adopted as the preferred method for removing/reassembling thrust collars, auxiliary gears and coupling hubs on almost all Rolls-Royce power turbines in operation in the North Sea. Other platform operators, too, are gradually phasing out costly open flame methods in favor of induction heating.

The Bruce Platform project was one in a series of breakthroughs in recent years for EFD Induction in the North Sea. Says Evans in conclusion: “It was great to be trusted by such well-known companies as BP and Rolls-Royce. It was a vindication of everything we’ve been saying about induction heating—its speed, mobility, controllability and safety. But it was also great to be nominated for a BP Helios Partnership award.” The award referred to by Evans is a prestigious recognition by BP of external partners ‘delivering over and beyond what is expected contractually, demonstrating true team spirit.’

Induction heating has been adopted as the preferred method for removing/reassembling thrust collars, auxiliary gears and coupling hubs on almost all Rolls-Royce power turbines in operation in the North Sea.

Land-based case story

The village of Orkanger near the Norwegian city of Trondheim is home to an important pipe assembly workshop for oil and gas pipelines to and from North Sea oil fields.

One of the companies working at Orkanger is Thermotite Bredero Shaw, Norway. Part of their job is to coat pipes with a special epoxy prior to coating with Polypropylene. This helps prevent leakage and corrosion in the pipes, enabling them to remain submerged in salt water for decades.

In order to successfully apply the epoxy, the outside of the pipes must first be heated. The heat has to be uniform across the application area, and the temperature must remain within a very narrow band. Both these conditions must be met in order for the epoxy to adhere properly to the pipe surface.

EFD Induction's involvement with the project began with a phone call from Thermotite Bredero Shaw one Friday. There was a problem with their conventional pipe heating equipment. Could EFD Induction help them get back into production on Monday? The experts at EFD Induction Norway's HQ said it was worth a try, so they put an engineer and a mobile Minac 18/25 demo heating unit into a van and set off on the 700 km drive to Orkanger.



The mobility of the EFD Induction Minac makes it ideal for on-site heating jobs in the offshore industry. Despite its compact size, the Minac offers integrated output matching, which enables it to handle applications as diverse as brazing, shrink fitting, hardening, curing, straightening, heat treatment, etc.

WHITE PAPER

from EFD Induction

The engineer reported for duty on Monday morning and started trial heating with the Minac 18/25. The job was made more complicated by having to hold a consistent temperature across areas consisting of weld seams joined to steel brackets. However, the engineer quickly found a way to scan the areas with a low temperature for two to three minutes, enabling the epoxy to be applied without any problems.

The customer was of course delighted to be back in production by Monday afternoon. But even we were taken aback when they wanted to keep the Minac 18/25 mobile induction heater. Although it was a demo unit, it had performed so well that the Thermotite Bredero Shaw technicians insisted on keeping it on site.

Subsea case story

EFD Induction played a key role in the Statoil Tampen Link project in the North Sea. The goal of the project—for which Technip Norway was the main contractor—was to connect the Statfjord field gas export line with the Shell UK FLAGS (Far North Liquids and Associated Gas System) export pipeline. The connection involved bringing a 12” branch pipe into a live, high-pressure 20” main gas line at a depth of 145 m (475’). Joining the two pipes—while still maintaining a high-pressure flow of gas in the main line—called for the use of ‘hot tapping’. Put simply, hot tapping involves welding a blind branch onto the main, live pipe. A ball valve is then attached to the blind branch. A special hot tapping machine is then attached to the valve assembly. This machine is basically a large drill that cuts a hole through the main pipe. The cut-out metal (called a ‘coupon’) is retrieved, the valve closed and the drill removed.

Hot tapping is a challenging operation. One of the more serious problems facing engineers is a heat-sink effect caused by the high-pressure flow of gas inside the main pipe. Any heat introduced into the main pipe is immediately removed by this fast-flowing cooler gas. The heat-sink is especially problematic because the first step in hot tapping is the application of a ‘butter layer’ or ‘butter weld’ on the outside of the main pipe. The branch is welded onto the butter layer, which acts as a transitional zone giving desired metallurgical qualities. However, the application of the butter layer, as well as the subsequent welding, calls for pre-heating. And it is this pre-heating that is difficult to achieve because of the heat-sink effect.



Photo : Technip Norge AS

Welding the branch pipe onto the live, pressurized main pipe. The coil induction is wrapped in white insulating material.

The traditional way to pre-heat a live pipe in preparation for a butter layer is to wrap the pipe with heating mats. However, the large size of the main pipe in the Tampen project (20”) and the massive cooling effect caused by the flow of pressurized gas (approx. 150 bar / 2175 psi) ruled out the use of such mats, as the radiated heat would make working conditions intolerable for the welder divers. Induction heating, however, produces heat directly within the workpiece, in this case the surface of the pipe. Also, profiled induction coils ensure that heat is generated only in very precisely defined locations and to precise depths. These features mean that intense and controllable heat is induced in the pipe, but with only negligible increases in the ambient temperature.

WHITE PAPER from EFD Induction

Minimal diver operations

The induction pre-heating solution devised for the Tampen project involved three induction coils, two shaped to fit the main pipe, and one shaped to heat the branch pipe. The solution also included 16 thermocouples placed in the heating zones and weld areas. As a key objective of the system was to minimize the divers' manual operations, most control functions were either automated or allocated to the topside team. Only the induction coils and the thermocouples were brought into the welding habitat.

The supply power on deck was standard ship voltage of 440 V at 60 Hz. This was stepped up to 1,200 V to minimize the size of the main umbilical. A subsea transformer stepped the voltage back down to 440 V at 60 Hz. The EFD Induction inverters then stepped the voltage above 700 V and increased the frequency to a very high kHz range. The cables to the coils terminated in compact hand-held transformers, which converted the voltage to below 28 V. This resulted in induction coils operating at low voltage but very high frequency. Perry Slingsby Systems Ltd. (PSSL) packaged the system for subsea operations, providing all the power, instrumentation, control and operations support.

Submerged for five days

The pre-heat and welding operations were extensively tested at the UK's National Hyperbaric Centre in Aberdeen. These tests confirmed that induction had the precision and power to offset heat-sink effects in the weld areas. The testing also gave engineers a chance to assign a power trip alarm to each thermocouple—an important safeguard to prevent overheating and possible collapse of the main pipe. The alarms were then fitted with delays. This was in order to avoid false warnings being

triggered whenever the welding stick passed a thermocouple, resulting in a momentary temperature spike.

The subsea phase of the operation was carried out from the *CSO Wellservicer*, a Technip diving support vessel. Technip also provided the subsea welding habitat. The pre-heating subsea work skid was supported by an umbilical reeler on the ship. A single container on the ship's deck provided all the power and many of the controls needed for the entire pre-heating operation. The

The blue container housed many of the controls needed for the pre-heating operation. Locating as many functions as possible topside improved working conditions for the diver welders. The white structure on the right is the subsea welding habitat. (Photo credit: Technip Norge AS.)



Photo : Technip Norge AS

WHITE PAPER

from EFD Induction

induction pre-heating system was deployed on the seabed for a total of five days and remained powered up throughout. The pre-heat system operated throughout all the welding, and there were no major equipment or safety incidents. Indeed, the pipe branch and the flange were successfully welded in place on the very first attempt.

This first deployment of the EFD Induction/PSSL Inductive Pre-heat System on a hyperbaric pipeline weld was a resounding success. It demonstrated that induction heating could help ensure:

- A compact and easy-to-build installation around the weld
- A very precise degree of temperature control during the preheating phase
- A pre-heating solution fully compliant with the latest diving personnel safety rules and all relevant electrical and magnetic field safety guidelines
- A compact deck-spread and a single power and control umbilical to the seabed
- Real time temperature trend monitoring and recording
- A comfortable and productive working environment for the welder divers



Photo : Technip Norge AS

The subsea work skid is hoisted aboard the support vessel. Most of the equipment needed for the preheating was housed in this skid and a container on the ship's deck. Only the coils and the thermocouples were brought into the subsea habitat.

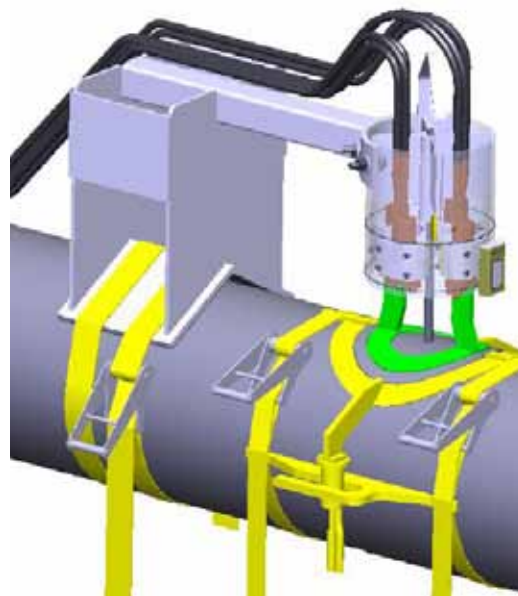

Photo : Technip Norge AS

A diagram explaining how two profiled coils were fitted against the live pipe. These coils warmed the face of the pipe so a butter layer could be laid down.

How it works

Alternating current flowing through a coil generates a magnetic field. The strength of the field varies in relation to the strength of the current passing through the coil. The field is concentrated in the area enclosed by the coil; while its magnitude depends on the strength of the current and the number of turns in the coil. (Fig. 1)

Eddy currents are induced in any electrically conductive object—a metal bar, for example—placed inside the coil. The phenomenon of resistance generates heat in the area where the eddy currents are flowing. Increasing the strength of the magnetic field increases the heating effect. However, the total heating effect is also influenced by the magnetic properties of the object and the distance between it and the coil. (Fig. 2)

The eddy currents create their own magnetic field that opposes the original field produced by the coil. This opposition prevents the original field from immediately penetrating to the center of the object enclosed by the coil. The eddy currents are most active close to the surface of the object being heated, but weaken considerably in strength towards the center. (Fig. 3)

The distance from the surface of the heated object to the depth where current density drops to 37% is the penetration depth. This depth increases in correlation to decreases in frequency. It is therefore essential to select the correct frequency in order to achieve the desired penetration depth.

The smarter heat—induction exploits basic electromagnetic laws to generate controllable heat directly in the workpiece. At no time does the coil touch the workpiece.

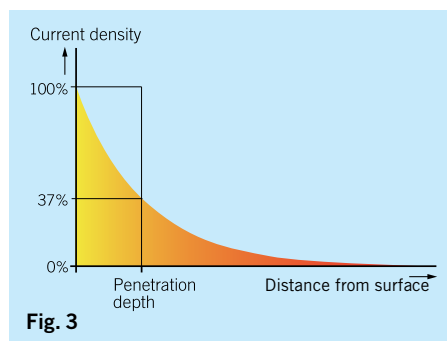
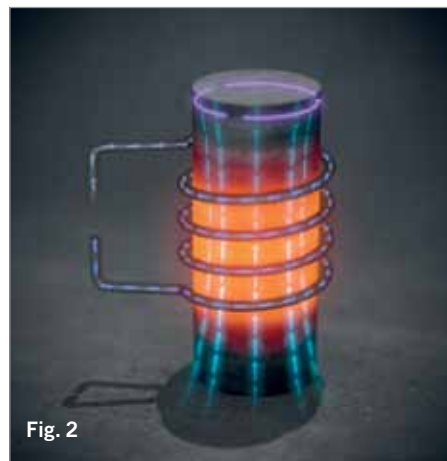
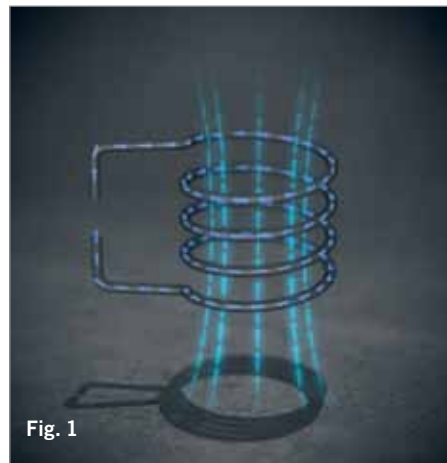

Selecting the best solution

Just how efficient is induction heating? What frequencies are best suited to your applications? The guide below will give you some idea of induction's potential. To learn more, just contact your nearest EFD Induction office or representative.

How much energy do you need?

Before calculating your energy requirements you first need to know:

- **The type of material (steel, copper, brass, etc.)**
- **Workpiece dimensions**
- **Desired hourly production**
- **Desired final temperature**

Calculate your energy requirements

Step 1 First determine the material's energy absorption rate. Fig. 4 shows rates for some common materials.

Step 2 Multiply the energy absorption rate by your desired hourly production (kg/hour). The result is your specific power requirement.

Step 3 You can now ascertain the overall efficiency level of the induction equipment. Some typical induction heater efficiency levels for common materials are listed in Fig. 5. Divide the calculated specific power need by the equipment efficiency rate. This gives you the total power requirement.

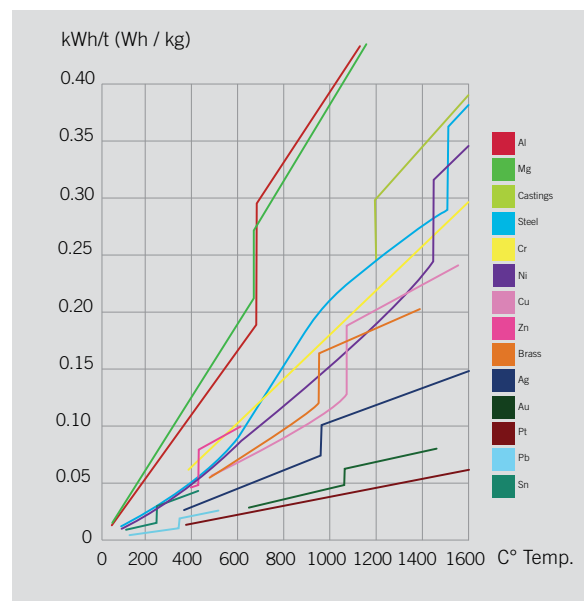

Fig. 4. Energy absorption rates for different materials

Material	Final temp. °C	Efficiency
Carbon steel	1250	0.65
Carbon steel	700	0.80
Stainless steel	1250	0.60
Brass	800	0.50
Copper	900	0.40
Aluminum	500	0.40

Fig. 5. Typical induction heater efficiency levels. The above values assume the use of enveloping multi-turn coils. Different coil designs may affect efficiency levels. For instance, the efficiency rate for copper is, because of the coil type normally used, usually 0.1-0.2.

WHITE PAPER from EFD Induction

Selecting the right frequency

The choice of frequency is crucial when using induction heating, as frequency determines the heat's penetration depth. Fig. 6 shows approximate frequencies for through-heating some common materials.

Material					Frequency
Steel non-magnetic	Steel magnetic	Brass	Copper	Aluminum and aluminum alloys	
Final temp. 1,200°C	700°C	800°C	850°C	500°C	
Ø mm	Ø mm	Ø mm	Ø mm	Ø mm	Hz
150–500	27–75	110–	50–	50–	50
60–250	8–35	35–440	22–800	22–800	500
40–175	6–25	30–300	15–600	15–600	1,000
25–100	3.5–14	15–180	9–350	9–350	3,000
20–85	2.5–10.5	10–130	7–260	7–260	5,000
14–60	2–8.5	8–100	5–180	5–180	10,000
10–40	1.5–5.5	6–75	3–125	3–125	20,000
5–22	0.7–3.0	3.5–40	2–75	2–75	60,000
4–17	0.5–2.0	2.5–30	1.5–60	1.5–60	100,000
1.8–8	0.2–1.0	1.2–15	0.6–20	0.6–20	500,000

Fig. 6. Some economically beneficial ranges of dimensions for common materials at different frequencies. The frequencies shown are approximate guides only. The shortest heating time for specific materials and dimensions is achieved by operating close to the lowest possible frequency limit.

The induction coil— a critical component

Correctly designed and built induction coils are absolutely critical for successful, cost-effective induction heating. In fact, designing and testing coils is often the process with the longest lead time when devising an induction heating solution. A key reason for this is the fact that coils are task specific. They must be designed to achieve specific results on specific materials under specific conditions. There are no—or at least there shouldn't be—'off-the-shelf' coil designs.

Rigorous testing of a coil's design and construction is essential. Too few people realize that coils are often the part most exposed to harsh operating conditions. Testing and computer-aided simulation are therefore sometimes needed to arrive at a design that is both safe and fatigue resistant. And of course, it takes repeated testing to achieve optimal part-heating patterns.



An induction coil specially designed and built for offshore industry requirements. Once heated by the coil (in red), the pipe can receive an anti-corrosion covering.

WHITE PAPER

from EFD Induction

Nothing can be taken for granted when designing induction coils. With very high power density coils, for example, one even needs to determine the correct speed at which cooling water should flow through the coil. Too low a speed will result in insufficient thermal transference. But even when the correct speed has been found, the coil designer must decide whether a booster pump is necessary in order to achieve and maintain the desired water through-flow rate. The competent coil designer will also specify a purity level for the cooling water, in order to minimize corrosion on the inside of the coil. So something as apparently straightforward as the coil's water, is in fact a complex matter demanding technical competence and specialist equipment.

The science of concentration

Magnetic flux concentrators are another area of an overall induction solution that at first glance seems relatively straightforward. As the name suggests, the main function of such concentrators is to concentrate the coil's current in the area of the coil facing the workpiece. Without a concentrator, much of the magnetic flux is free to propagate around the coil. This uncontrolled flux will then 'engulf' adjacent conductive components. But when channelled by a concentrator, the magnetic flux can be restricted to precisely defined areas of the workpiece, resulting in the localized heating zones characteristic of induction heating.



Photo : Technip Norge AS

Specialist coils being tested for the Tampen subsea hot tapping project. See pp. 12-14 for more details about this technically advanced use of induction heating in the offshore industry.

Many variables must be considered when making flux concentrators. The workpiece's material, the coil's shape, the application—each influences the concentrator's final design. Even deciding what material to use for the concentrator can be a complicated task. Basically, concentrators are made from laminations, or from pure ferrites and ferrite- or iron-based powders.

Each concentrator material has its own drawbacks and advantages. Laminations have the highest flux densities and magnetic permeability; they are also less expensive as parts than iron- and ferrite-based powders. Laminations must however be stamped to a few standardized sizes and are therefore less flexible. They are also labor intensive to mount. Pure ferrites can also offer outstanding magnetic permeability. However, they suffer from low saturation flux density, and their brittleness makes them difficult to machine (diamond-tipped cutters must be used). Iron powders are easy to shape, offer high flux densities, and are easy to shape. But great care must be taken to provide against over-heating, as internal losses or heat transfer from the heated part means such powders have a relatively low working temperature.

WHITE PAPER

from EFD Induction

Of course, many other factors need to be considered when designing induction coils. Correct impedance matching between the coil and the power source, for instance, is crucial in order to use the full power from the power source. Plus the fact that coils need five to ten times as much reactive as active power. Then there is the science of choosing the appropriate electrical insulation: should the coil be dipped in an epoxy coating, or should it be molded with high-temperature concrete? Again, these are complicated decisions influenced by several variables.

A professionally designed and fabricated induction coil is an advanced, complex component. Unfortunately, too many induction users persist in viewing coils as low-tech copper tubes. The results of this misconception are incorrect—even dangerous—coil designs, amateurish repairs, insufficient or incorrect maintenance, and ultimately, process and equipment failures.



High-throughput post-weld induction heat treatment of offshore pipe.

EFD Induction has to date installed thousands of heating solutions for a vast range of industrial applications—bringing the benefits of induction technology to many of the world's leading manufacturers and service companies. EFD Induction has manufacturing plants, workshops and service centers in the Americas, Europe and Asia.

Learn more about EFD Induction and our solutions that are boosting productivity for companies around the world. Visit: www.efd-induction.com